



MS7220 ArgusSCAN®

ArgusSCAN® is an on counter, hands free bar code scanner. The omnidirectional scan pattern creates a large scan area, maximizing performance in medium-to-high throughput POS applications.

Metrologic's ArgusSCAN is an aggressive omnidirectional laser bar code scanner. Fully automatic scanning operation makes it ideal for retail, convenience, liquor, grocery and specialty stores. Because it is engineered with a large, high-speed scan area and a bright 650 nm laser, ArgusSCAN boasts exceptionally high first pass read accuracy for maximum productivity.

Offering four stand configurations, the ArgusSCAN is adaptable to a variety of applications. The modular design allows it to be mounted on a counter, in a horizontal or vertical configuration. An optional flex-stand can be added, raising the scanner an additional 76 mm (3") off the counter

top. Combine this with the ArgusSCAN's programmable depth of field, and ArgusSCAN can be customized to meet the requirements of even the most unique scanning environment.

Multiple interfaces and data parsing make the ArgusSCAN compatible with most cash registers right out of the box, and the RS232 auxiliary port allows for check readers, magstripe readers or bar code scanner input. Simply plug a Metrologic hand-held scanner into the auxiliary port for scanning bulky or heavy items.

The MS7220 is OPOS and JPOS compatible and with Metrologic's PowerLink user replaceable cables, users can quickly replace cables if they become damaged.

www.metrologic.com



FEATURES

- Firmware updates via Flash ROM
- Electronic article surveillance built in
- Field replaceable window
- Auxiliary port
- User-replaceable cables

BENEFITS

- Update firmware from any PC via MetroSet2® software provided free
- Reduces shrink
- Fast repairs without removing unit from service
- Connect an external scanner or other peripheral directly to the scanner
- Uses the same user-replaceable cables and power supply as Orbit® and Cubit®

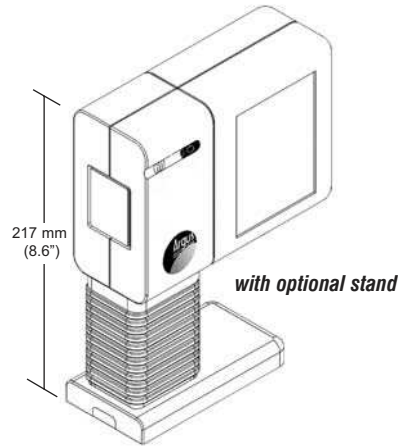
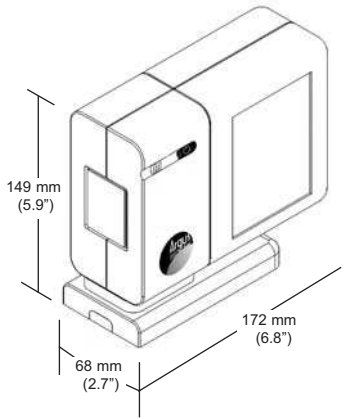

OPERATIONAL

Light Source	Visible Laser Diode 650 nm ± 10 nm
Laser Power	0.678 mW (peak)
Decode Capability	Autodiscriminates all standard bar codes; for other symbologies call Metrologic
System Interfaces	PC Keyboard Wedge, RS232, OCIA, Light Pen Emulation, IBM 468x/469x, Stand Alone PC Keyboard, USB
Number Characters Read	Up to 80 data characters
Beeper Operation	7 tones or no beep
Indicators (LED)	Green = laser on, ready to scan; Red = good read, decoding

MECHANICAL

Dimensions	149 mm H x 68 mm D x 172 mm W (5.9" H x 2.7" D x 6.8" W)
Footprint On Stand	127 mm x 68 mm (5" x 2.7") or 93 mm x 68 mm (3.5" x 2.7")
Weight	0.91 kg (2 lbs)
Termination	Four 10-pin modular RJ45
Cable	Standard 2.1 m (7') straight; optional 2.7 m (9') coiled; for other cables call Metrologic
Mount (optional)	Fully adjustable

ELECTRICAL

Input Voltage	5.2 VDC ± 0.25 V
Power	1.9 W
Operating Current	360 mA
DC Transformers	Class II; 5.2 VDC @ 1 A
Laser Class	CDRH: Class IIa; EN60825-1:1994/A11:1996 Class 1
EMC	FCC, ICES-003 & EN55022 Class A

ENVIRONMENTAL

Operating Temperature	0°C to 40°C (32°F to 104°F)
Storage Temperature	-40°C to 60°C (-40°F to 140°F)
Humidity	5% to 95% relative humidity, non-condensing
Light Levels	Up to 4842 Lux (450 footcandles)
Contaminants	Sealed to resist airborne particulate contaminants
Ventilation	None required

SCAN PERFORMANCE

Depth of Scan Field	0 mm - 215 mm (0" - 8.5") for 0.33 mm (13 mil) bar code
Width of Scan Field	38 mm (1.5") @ 40 mm (1.6"); 135 mm (5.3") @ 215 mm (8.5")
Scan Speed	2000 scan lines per second
Scan Pattern	5 fields of 4 parallel lines (omnidirectional)
Number of Scan Lines	20
Minimum Bar Width	0.13 mm (5.2 mil)
Print Contrast	35% minimum reflectance difference
Roll, Pitch, Yaw	360°, 60°, 60°

Scan Area

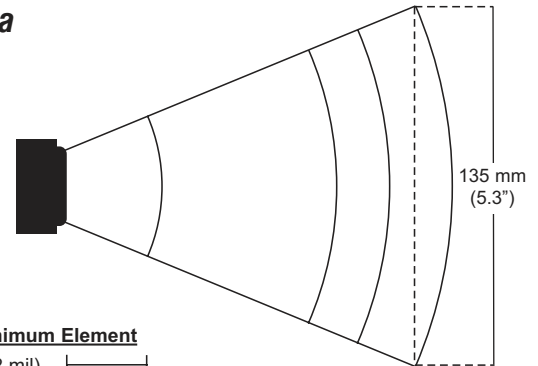

Bar Code Minimum Element

0.132 mm (5.2 mil)	
0.191 mm (7.5 mil)	
0.264 mm (10.4 mil)	
0.330 mm (13.0 mil)	

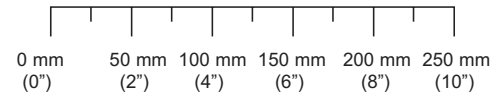

Product Colors Available



MS7320 is available in a variety of other colors with minimum quantity purchase



Sunrise 2005 Compliant



www.metrologic.com

ISO 9001:2000

Metrologic Instruments, Inc. | Worldwide Headquarters

90 Coles Road | Blackwood, NJ 08012-4683 | info@metrologic.com

Telephone 856-228-8100 | Fax 856-228-6673

Asian Headquarters
Tel. 65.6842.7155
info@sg.metrologic.com

European Headquarters
Tel. 49.89.89019.0
info@eu.metrologic.com

The Americas Headquarters
Tel. 1.800.ID.METRO
info@us.metrologic.com

Specifications subject to change without notice.
Printed U.S.A., Copyright November 2005
Metrologic, All rights reserved.



DS7220